

Source: Leece-Neville Heavy Duty Systems Division - Arcade, NY USA
Date: July 7, 2017
Bulletin No: TSB-1116
Models: MDA/ MDP
Subject: Converting to remote regulator

This procedure will explain how to convert an internal regulated alternator to use an external regulator.

Item needed: Qty. 1 (K185103982S)
Remote regulator cover.

Step 1: Remove hardware from alternators positive, negative, AC and D+ posts. (Fig. 2)

Step 2: Remove red, black and yellow regulator wires from alternator positive, negative, AC and D+ posts. (Fig. 3)

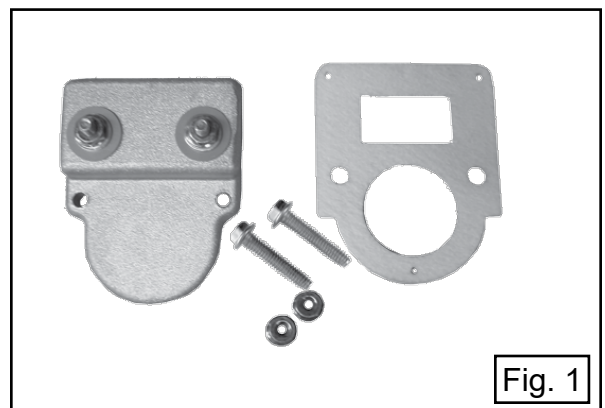

Fig. 1

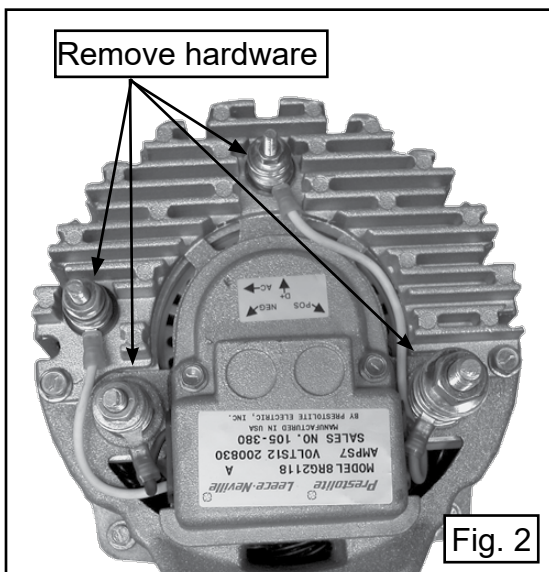

Fig. 2

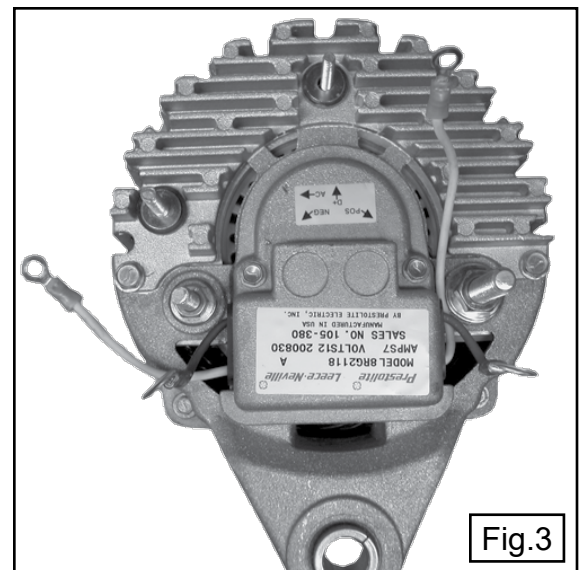

Fig. 3

Important: The information contained in this bulletin is intended for use by trained, professional technicians who have the proper tools, equipment, and training to perform the required maintenance described above. This information is NOT intended for 'do-it-yourselfers'; and you should not assume that this information applies to your equipment. If you have any questions regarding this information please visit our website at www.prestolite.com, or contact our technical service department at:

Date: July 7, 2017

Bulletin No: TSB-1116

Step 3: Remove two screws attaching regulator to alternator. (Fig. 4)

Step 4: Tilt regulator away from alternator and remove the two green field wires. (Fig. 5)

Regulator wires are attached to alternator with spade terminals. Use needle nose pliers to remove these wires.

Step 5: Remove regulator and gasket from alternator.

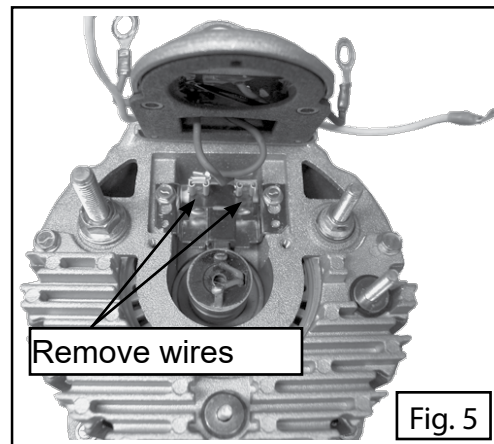
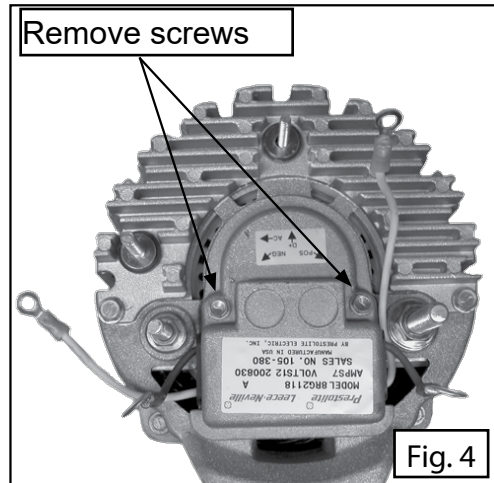

Important: The information contained in this bulletin is intended for use by trained, professional technicians who have the proper tools, equipment, and training to perform the required maintenance described above. This information is NOT intended for 'do-it-yourselfers', and you should not assume that this information applies to your equipment. If you have any questions regarding this information please visit our website at www.prestolite.com, or contact our technical service department at:

Date: July 7, 2017

Bulletin No: TSB-1116

Step 6: Place gasket furnished with kit onto alternator. (Fig.6)

Step 7: Place remote regulator cover on alternator and attach two green wires to alternator brushes. (Fig. 7)

Note: Polarity of green field wires is not critical. Connect wires where they will not be pinched during assembly.

Step 8: Install two screws holding remote regulator cover to alternator. (Fig.8)
Torque screws to 25-30 in-lbs.

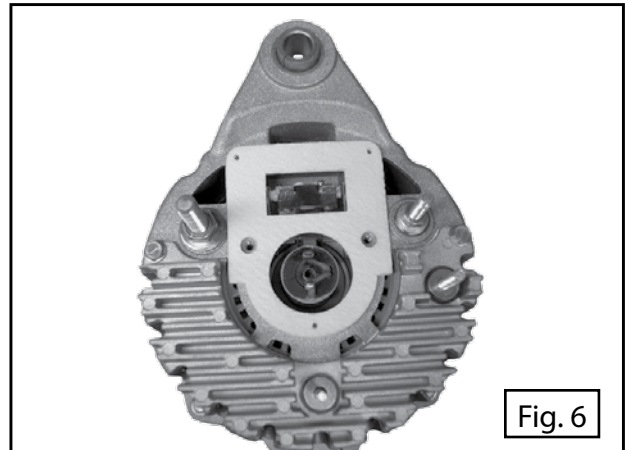
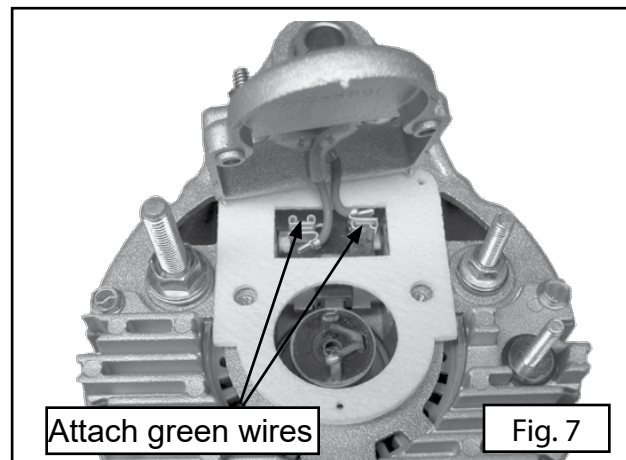
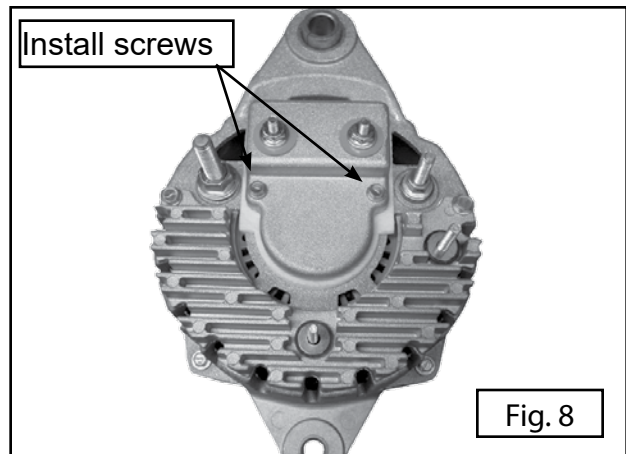

Fig. 6



Attach green wires

Fig. 7



Install screws

Fig. 8

Important: The information contained in this bulletin is intended for use by trained, professional technicians who have the proper tools, equipment, and training to perform the required maintenance described above. This information is NOT intended for 'do-it-yourselfers'; and you should not assume that this information applies to your equipment. If you have any questions regarding this information please visit our website at www.prestolite.com, or contact our technical service department at:

Date: July 7, 2017

Bulletin No: TSB-1116

Step 9: Install positive, negative, AC and D+ hardware onto the alternator.

Torque negative nuts to 35-44 in-lbs.

Torque positive nuts to 71-80 in-lbs.

Torque AC nuts to 35-44 in-lbs.

Torque D+ nuts to 18-22 in-lbs.

Refer to (Fig 9) for proper orientation of positive, negative, AC and D+ hardware.

Step 10: Conversion complete.

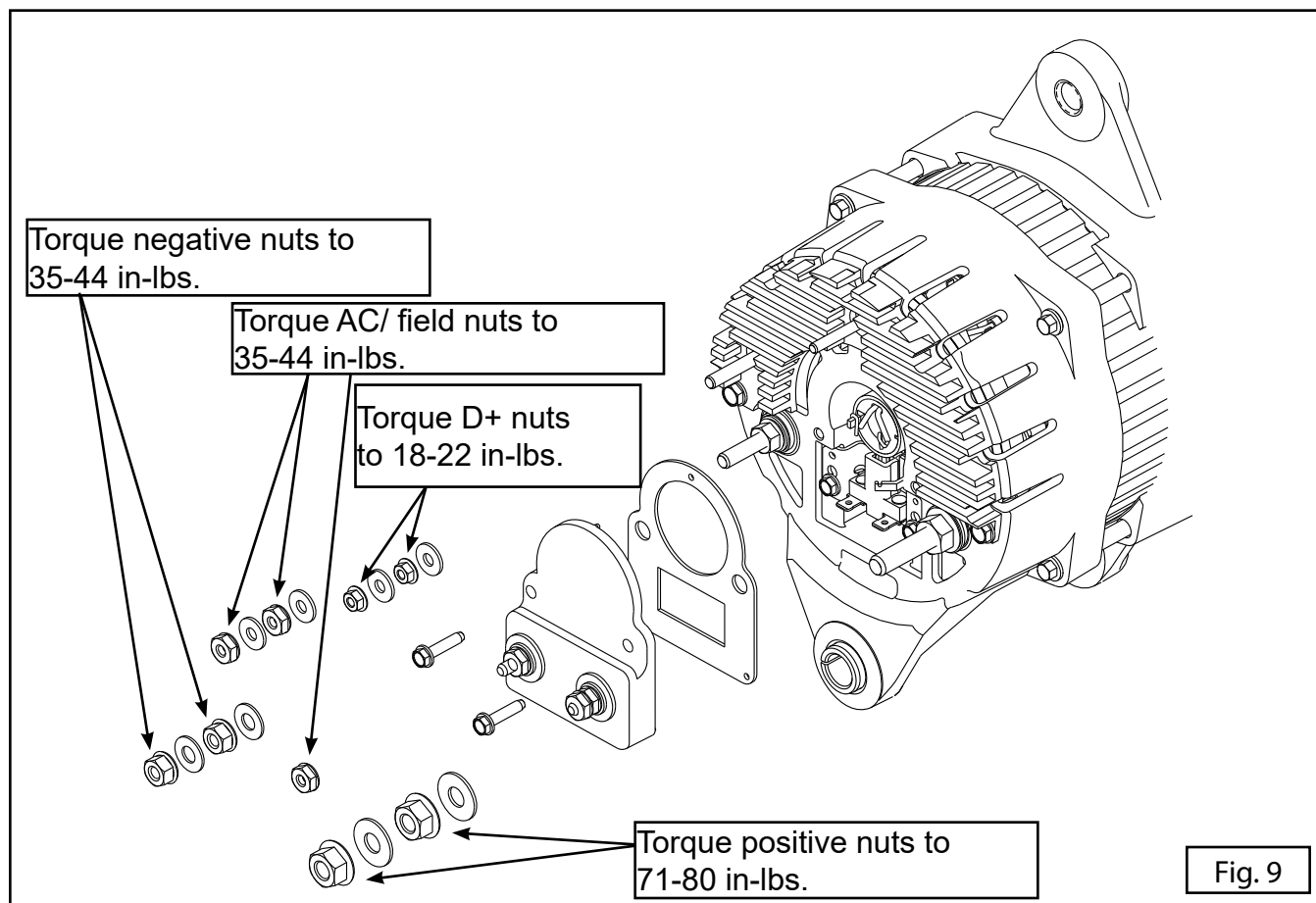

Important: The information contained in this bulletin is intended for use by trained, professional technicians who have the proper tools, equipment, and training to perform the required maintenance described above. This information is NOT intended for 'do-it-yourselfers', and you should not assume that this information applies to your equipment. If you have any questions regarding this information please visit our website at www.prestolite.com, or contact our technical service department at:

Date: July 7, 2017

Bulletin No: TSB-1116

Alternator wiring

Please refer to the installation instructions that came with your voltage regulator.

Terminology definitions:

(“A” or “N”): “A”- Regulator is installed after alternator’s field.

“N”- Regulator is installed on alternators negative side of field.

(“B” or “P”): “B”- Regulator is installed before alternator’s field.

“P”- Regulator is installed on alternator’s positive side of field.

You will either have an (“A” or “N”) type or (“B” or “P”) type external voltage regulator. Please refer to (Fig 10 or 11) to correctly wire the alternator field to properly work with your regulator.

Use a 12 AWG wire in the figures below.

Fig 10: (“A” or “N”) type regulators

Fig 11: (“B” or “P”) type regulators

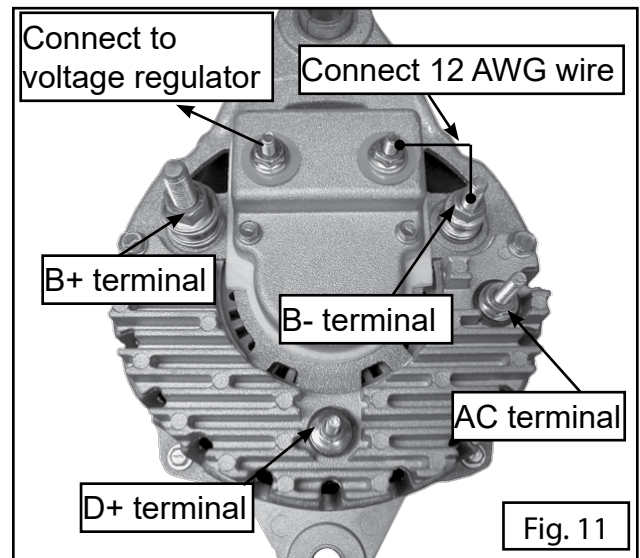
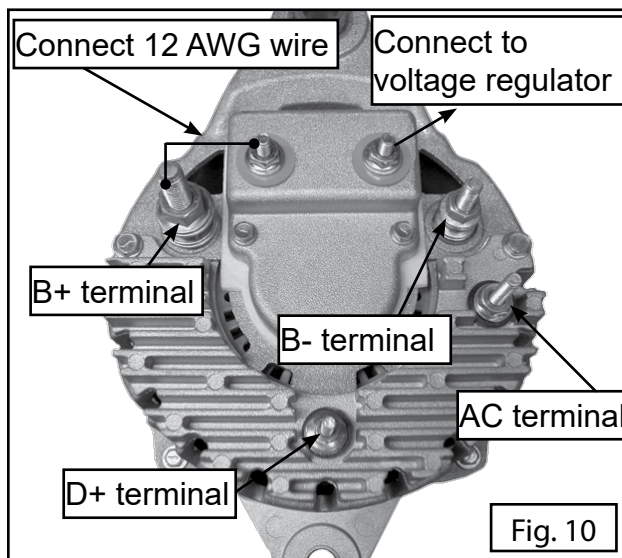

Important: The information contained in this bulletin is intended for use by trained, professional technicians who have the proper tools, equipment, and training to perform the required maintenance described above. This information is NOT intended for ‘do-it-yourselfers’; and you should not assume that this information applies to your equipment. If you have any questions regarding this information please visit our website at www.prestolite.com, or contact our technical service department at: